



The BREWBUILD SYSTEM

www.brewbuild.co.nz • nzbrewbuild@gmail.com

How to install your weldless sightglass

Parts supplied

- Sightglass with stainless 1/4" NPT 90° elbow (1)
- 2 x Stainless Washers 1/2" ID (2)
- 1 x Stainless Washer 1" (3)
- High temperature O ring (4)
- Stainless O ring lock nut (5)
- 1/2" Stainless Eye Bolt (6)
- Level marker stickers (7)

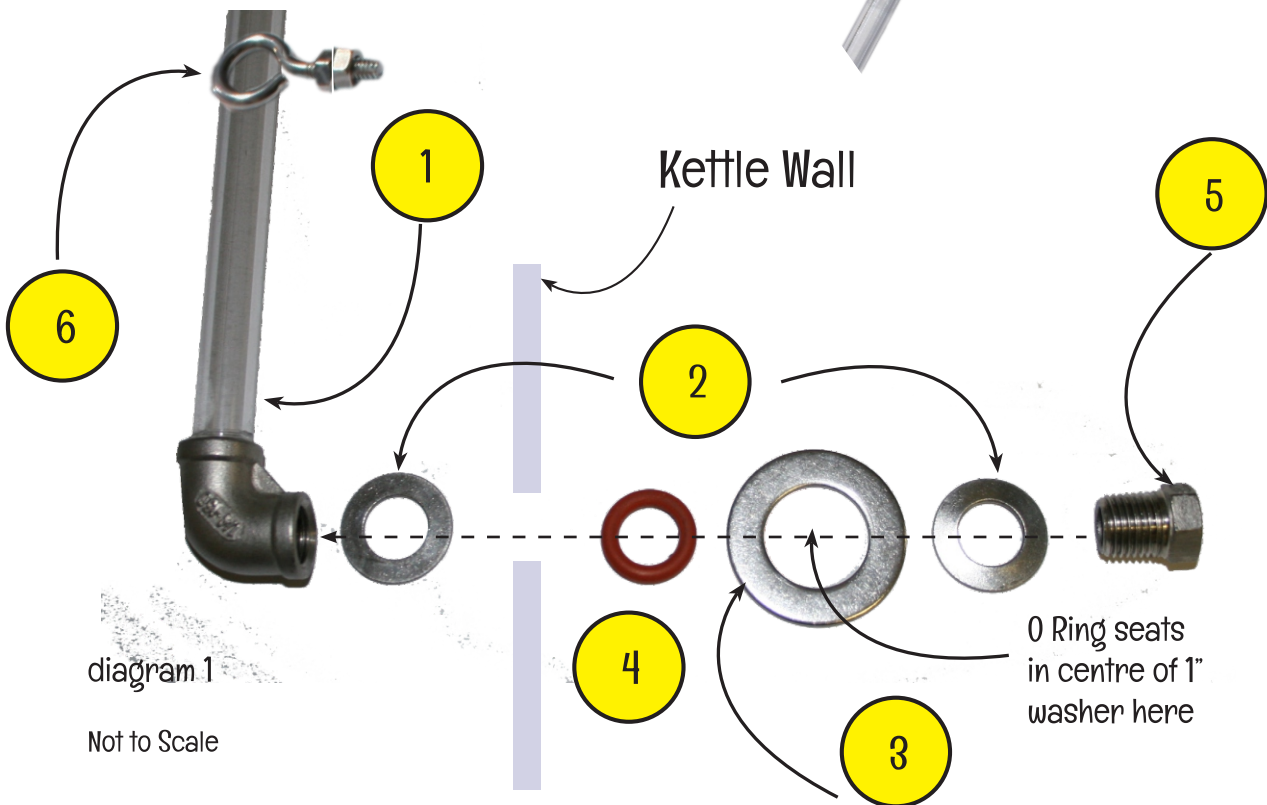
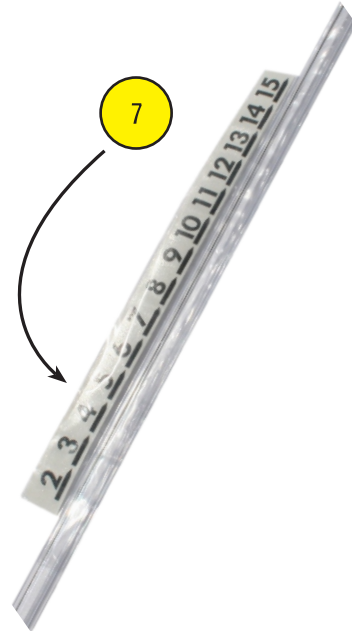

Installation

1. Mark your kettle where you would like the centre of the Sight Glass elbow to be installed
2. Cut a 1/2" (12mm) hole in the kettle using a chassis punch, or step drill bit, do not cut the hole too large or the O ring will not seal correctly and you run the risk of leaks.

continued...

3. File the edges of the hole and clean with abrasive paper to remove any sharp edges or burrs.
4. Fit the components as shown in diagram 1 and tighten the locking nut. DO NOT overtighten so that the O ring is squashed flat or leaks will occur. Sometimes it is necessary to experiment with the tightness of the locknut .

Note ... that the O ring should seat centrally within the 1" stainless washer so that when compressed it forms a water tight seal whilst only being compressed to the thickness of the washer.

5. Fill the kettle with water to above the sight glass elbow and check for any leaks.
6. Measure the amount of water you add to the kettle and cut your level marker stickers and fit to calibrate the sight glass.